



Станции горячего водоснабжения SANICIA T2 Технические характеристики

По вопросам продаж и поддержки обращайтесь:

Архангельск (8182)63-90-72

Астана +7(7172)727-132

Белгород (4722)40-23-64

Брянск (4832)59-03-52

Владивосток (423)249-28-31

Волгоград (844)278-03-48

Вологда (8172)26-41-59

Воронеж (473)204-51-73

Екатеринбург (343)384-55-89

Иваново (4932)77-34-06

Ижевск (3412)26-03-58

Казань (843)206-01-48

Калининград (4012)72-03-81

Калуга (4842)92-23-67

Кемерово (3842)65-04-62

Киров (8332)68-02-04

Краснодар (861)203-40-90

Красноярск (391)204-63-61

Курск (4712)77-13-04

Липецк (4742)52-20-81

Магнитогорск (3519)55-03-13

Москва (495)268-04-70

Мурманск (8152)59-64-93

Набережные Челны (8552)20-53-41

Нижний Новгород (831)429-08-12

Новокузнецк (3843)20-46-81

Новосибирск (383)227-86-73

Орел (4862)44-53-42

Оренбург (3532)37-68-04

Пенза (8412)22-31-16

Пермь (342)205-81-47

Ростов-на-Дону (863)308-18-15

Рязань (4912)46-61-64

Самара (846)206-03-16

Санкт-Петербург (812)309-46-40

Саратов (845)249-38-78

Смоленск (4812)29-41-54

Сочи (862)225-72-31

Ставрополь (8652)20-65-13

Тверь (4822)63-31-35

Томск (3822)98-41-53

Тула (4872)74-02-29

Тюмень (3452)66-21-18

Ульяновск (8422)24-23-59

Уфа (347)229-48-12

Челябинск (351)202-03-61

Череповец (8202)49-02-64

Ярославль (4852)69-52-93

сайт: www.ciat.nt-rt.ru | эл. почта: cta@nt-rt.ru

“
Packaged unit assembly
 for the **instantaneous and semi-instantaneous production** of domestic hot water
 A range of options
Electronic control
Anti-legionella treatment included

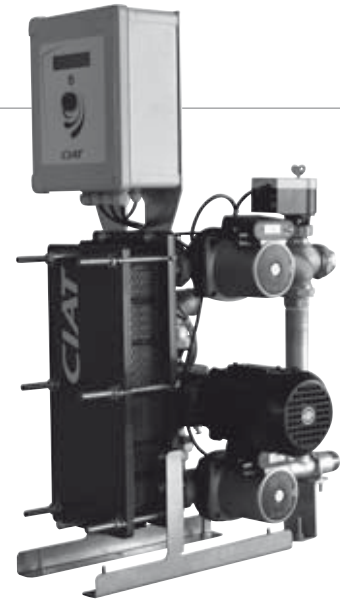

USE

SANICIAT2 is a module for the instantaneous, semi-instantaneous or accumulation production of domestic hot water. Supplied as a packaged unit, it is ready to connect thanks to its standard plumbing couplings and its electrics box supplied with wires pre-fitted with terminals.

This unit is designed to be installed in a machine room, protected from freezing temperatures and inclement weather in a location inaccessible to the public.

It is particularly suited to the Collective Housing, Hotel, Healthcare, Industry and Service Sector markets.

RANGE

SANICIAT2 is available in 23 sizes.
 Domestic hot water flow rate up to 12.3 m³/h (at 55°C for a primary of 90°C).

DHW temperatures adjustable up to 65°C.

Primary circuit max. temperature: 100°C.

Maximum authorised pressure on the primary circuit 10 bar; 7 bar on the DHW circuit.

COMPLIANCE

- Low Voltage Directive 2006/95/EC
- EMC Electromagnetic Compatibility Directive 2004/108/EC,
- Pressure equipment PED 97/23/EC

DESCRIPTION

Example of SANICIAT2 coding

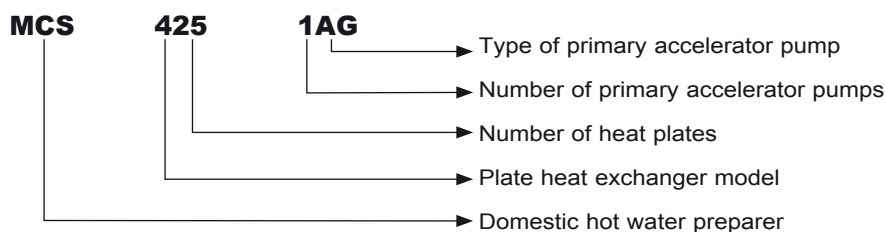

LOCATION OF COMPONENTS

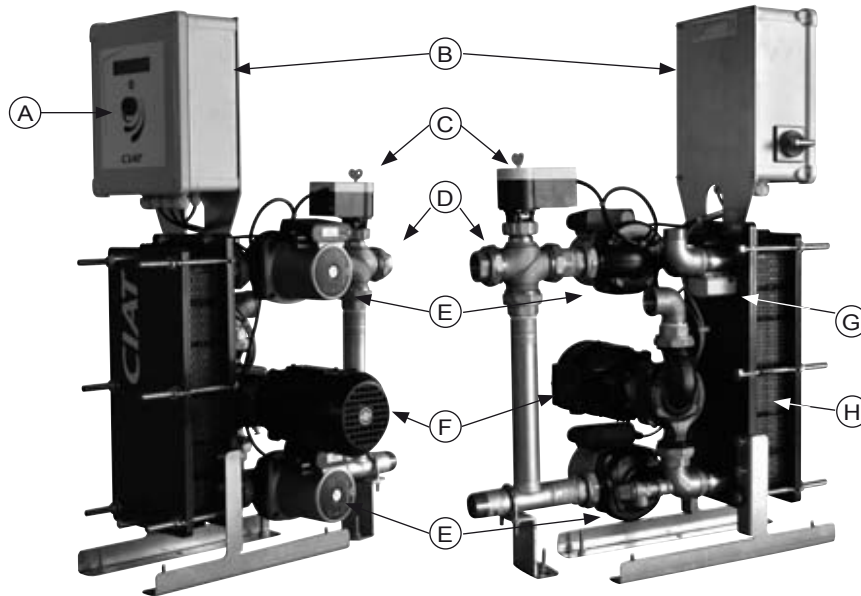

- (A) HMI with control button
- (B) Electrics box
- (C) Servomotor
- (D) Primary 3-way valve
- (E) Primary accelerator pump
- (F) Circulator (on tank in semi-instantaneous production)
- (G) Control sensor
- (H) Stainless steel plate 316L + NBR gaskets

DESCRIPTION OF THE MAIN COMPONENTS

■ Exchanger

- ITEX PWB 4+ ACS-certified range,
- Stainless steel 316L plates and NBR Plug-in[®] gaskets,
- Ready to be installed and connected.

■ Electrics and control box

- 230V- 1Ph-50 Hz + Earth supply,
- High/low safety temperature and control sensor (automatic or manual reset),
- Motorised primary 3-way valve with or without reset to zero,
- Rated safety valve on cold water,
- Electronic control featuring a simple, user-friendly menu: intuitive navigation thanks to the rotary selector on the front,
- 2 contacts for information feedback (operation and faults),
- ModBus/RTU RS 485 type 2-wire communication protocol, dialogue via CMS possible,
- Display of data and potential faults,
- Log of last 20 faults,
- Accelerator pump operation counter,
- Adjustable factory configuration.

■ Primary accelerator pump

- Single or dual primary for safe operation (with automatic switching).

■ Programming

There are two configuration levels:

Simple configuration (user/operator mode):

- timer,
- daytime and night-time DHW temperature setpoints,
- daily or weekly programming,

Advanced configuration (administrator mode):

- anti-legionella treatment: setpoint, duration, day etc.,
- the high/low safety and alarms thresholds,
- assignment of relays for information feedback,
- PID regulation,
- override operation (pump, opening 3-way valves etc.).

OPTIONS

■ Primary circuit

- Valve actuator with no-volt reset to zero (safety device in instantaneous production)

■ Single or dual DHW circulator (operation with DHW storage tank)

Supplied fitted.

There are two technologies to choose from depending on the water quality:



- A glandless cast iron accelerator pump body: the motor rotor is cooled by the driven fluid. As a result, however, this technology may not be best suited to a certain type of water prone to forming scale.



- A glanded stainless steel accelerator pump body: the motor is not in contact with the driven fluid. This technology is suited to aggressive fluids and therefore compatible with a broad range of water qualities.

■ Loop accelerator pump (supplied unconnected)

Only available in the glanded stainless steel accelerator pump body version for optimum reliability.

The customer is responsible for electric and hydraulic connection and the control.

■ Heat exchanger insulating material

- Thermoformed insulation composed of 2 pre-cut half-casings.

Light and resistant, it can be installed or removed without special tools. Limits losses by insulating the exchanger and its sealing strip completely.

■ HEE available

Consult us.



ACCESSORIES

■ DHW storage tank

- Vertical position, on feet,
 - Made from carbon steel panels,
 - Inner protection guaranteed by:
 - POLYWARM® internal sanitary coating,
 - Cathodic protection by magnesium anode as standard (2 anodes from 2000L),
 - Quick check of anode condition using an anode tester.
 - Gas connector type couplings,
 - Stainless steel directional cold water inlet,
 - Total drainage via Ø 2" coupling at the low point.
- Manhole on all models:
 - Int./ext. diameters 300/380 mm for 500, 800 and 1 000 litre capacities,
 - Int./ext. diameters 400/512 mm from 1 500 litres.
 - Max. allowable pressure (PS): 7 bar (effective),
 - Max. allowable temperature: 90°C,
 - Insulation (including manhole) factory fitted:
 - 50 mm flexible insulation and PVC material.
 - M1 fire rating,
 - 50 mm flexible insulation and fibreglass.
 - M0 fire rating.

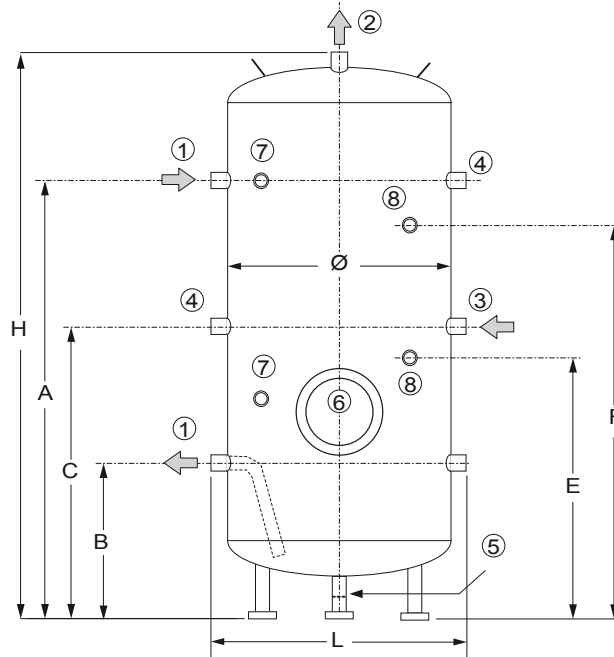

	Capacity (litres)	500	800	1000	1500	2000	2500	3000	
Ø	Diameter	650	750	850	950	1100	1250	1250	
	Empty weight (kg)	85	118	155	226	309	380	442	
H	Height	1841	2170	2224	2498	2492	2415	2915	
L	Width	750	850	950	1050	1200	1350	1350	
B	To MSC	416	465	486	493	592	600	600	
A	MSC return	1526	1825	1846	2103	2042	1940	2440	
C	Loop return	971	1145	1166	1298	1317	1270	1520	
E	Magnesium anode	971	1145	1166	1298	967	975	1025	
F	2 nd magnesium anode	-	-	-	-	1917	1815	2265	
①	MSC connection	1"1/4	1"1/4	1"1/2	1"1/2	2"	2"	2"	
②	DHW outlet	1"1/4	1"1/4	1"1/2	2"	2"	2"	2"	
③	DHW return (loop)	1"1/4	1"1/4	1"1/2	1"1/2	2"	2"	2"	
④	Other couplings	1"1/4	1"1/4	1"1/2	1"1/2	2"	2"	2"	
⑤	Drain	2"							
⑥	Manhole (int./ext. Ø)	300/380			400/512				
⑦	Instruments	1/2"							
⑧	Nozzles for anode	1"1/4							

Dimensions in mm

QUICK SELECTION

Depending on the temperature of the primary fluid, find the desired domestic hot water continuous flow rate in the corresponding column. For other temperatures, contact us.

■ Selection table

MSC	PRIMARY ACCELERATOR PUMP		PRIMARY HOT WATER						
			90°C		80°C		70°C		
			Power (kW)	DHW flow rate for 55°C (l/min)	Power (kW)	DHW flow rate for 55°C (l/min)	Power (kW)	DHW flow rate for 55°C (l/min)	
407	1.25	AM	62.9	20	49	16	35	11	
409	1.8		91	29	71	23	51	16	
411	2.4		121	38	94	30	68	22	
413	2.9		147	47	114	36	83	27	
415	3.5	AG	177	56	137	44	100	32	
417	4.1		207	66	163	52	117	37	
419	4.7		237	76	187	60	134	43	
421	5.2		264	84	207	66	148	47	
423	5.8		294	94	230	74	165	53	
425	6.4	BM	324	103	254	81	182	58	
427	7	BG	354	113	278	89	199	64	
429	7.6		384	122	302	96	216	69	
431	8.2	CP	414	132	325	104	233	74	
433	8.7		440	140	346	110	248	79	
435	9.3		470	150	368	118	265	85	
437	9.8		496	158	390	124	280	89	
439	10.3		523	167	410	131	294	94	
441	10.7		546	173	428	136	307	98	
443	11.1		568	182	445	142	319	102	
445	11.5		590	188	463	148	331	106	
447	11.8		CM	608	193	477	152	341	109
449	12			623	198	488	156	349	111
451	12.2	637		203	499	159	356	114	

Selection example

For 92 l/min with a primary temperature of 80°C, the table shows an MSC 429 equipped with a BG type primary accelerator pump (double: 2BG or single: 1BG)

Procedure for selecting the circulator, for semi-instantaneous DHW production:

- The DHW flow rate is 92 l/min, or 5.5 m³/h and the selected module an MSC 429.
- The flow rate per stream is therefore 394 l/h (pressure drop paragraph); the corresponding pressure drop is 2000 mmWC, or 2 mWC (curve A).
- Add 0.5 mWC (min. reserve for connecting pipe) to give 2.5 mWC.

Use the graphs (DHW accelerator pump: curves paragraph), to find the accelerator pump which, for a flow rate of 5.5 m³/h, has a manometric head of Hm ≥ 2.5 mWC.

The graph reading will suggest:

- Glandless technology: C3 model accelerator pump,
- Glanded technology: B model accelerator pump.

We recommend choosing glanded technology as this is compatible with a wide variety of water qualities.

ELECTRICAL SPECIFICATIONS

Primary accelerator pump

Model		AM	AG	BM	BG	CP	CM
Rated output	kW	0.2	0.22	0.34	0.345	0.61	0.68
Nominal current	A	0.9	0.98	1.5	1.52	3.18	3.47
Power supply	ph/Hz/V	1 ~ 50Hz 230V					

DHW accelerator pump

Model		Glandless						Glanded			
		C1	C2	C3	C4	C5	C6	A	B	C	D
Rated output	kW	0.13	0.2	0.22	0.28	0.34	0.34	0.12	0.12	0.25	0.25
Nominal current	A	0.6	0.9	0.98	1.3	1.5	1.52	1.05	1.05	1.05	2.05
Power supply	ph/Hz/V	1 ~ 50Hz 230V									

PRESSURE DROP

The pressure drop in a circuit (primary circuit or circuit for DHW) is determined using the graph below. To do this, you must calculate:

- Number of streams = (Number of plates - 1) / 2
The number of plates is indicated in the unit designation. (Example: MSC 429 = 29 plates, i.e. 14 streams)
- Flow rate per stream = Total flow rate / Number of streams

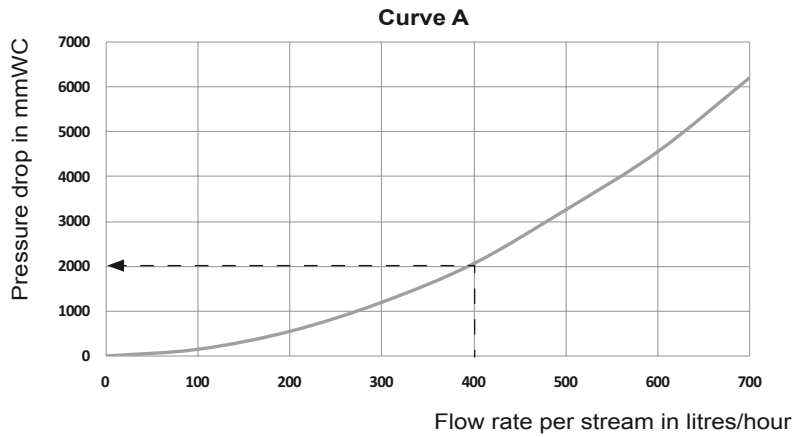

DHW ACCELERATOR PUMPS

Hydraulic specifications

Glandless load

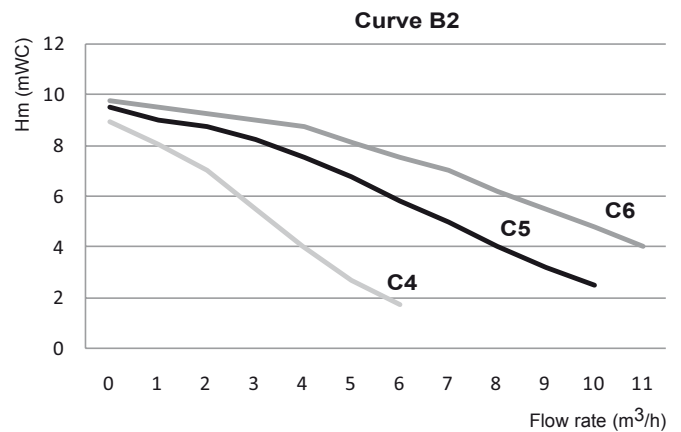
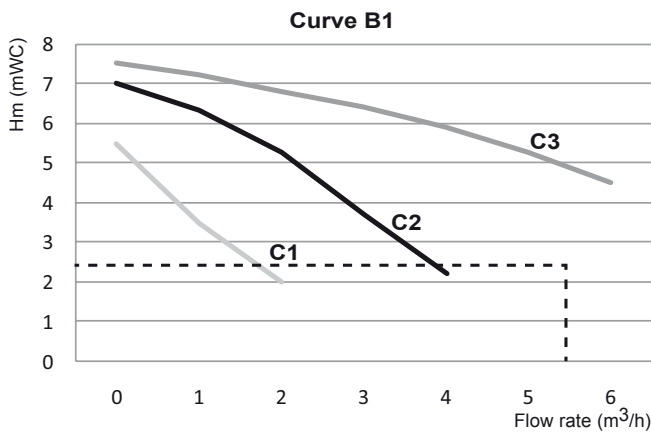

Glanded

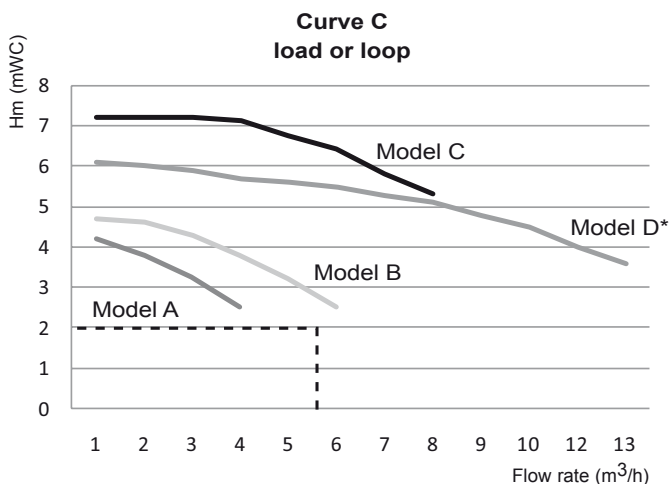

* Only with MSC 435 and MSC451 models

DIMENSIONS

MSC 407 to MSC 433

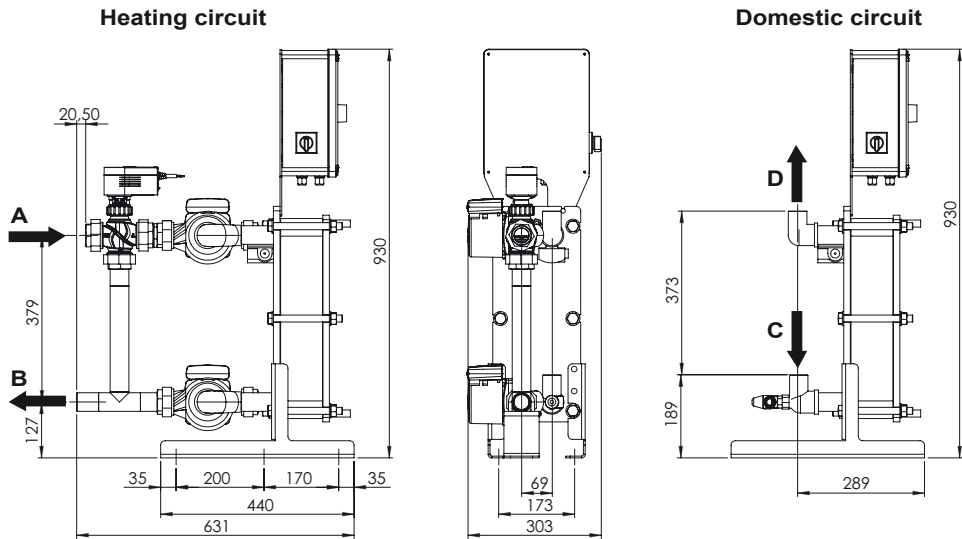

MSC 435 to MSC 451

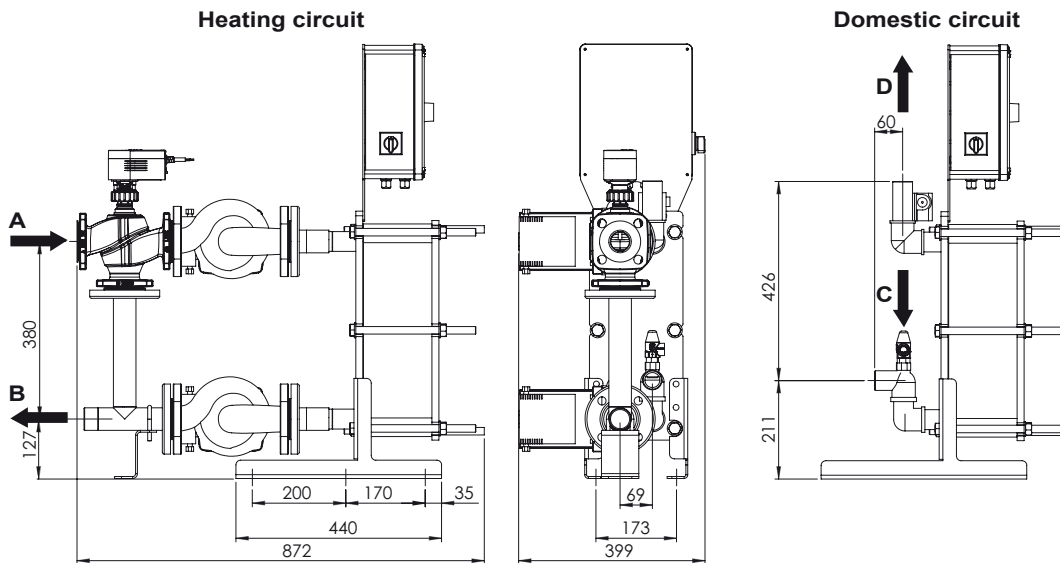

		MSC 407 to 433	MSC 435 to 451
A	Primary inlet	1"1/4 F	DN 40
B	Primary outlet	1"1/4 M	1"1/2 M
C	Municipal water (instantaneous production) or	1"1/4 M	1"1/2 M
C	Storage tank return (semi-instantaneous production)		
D	DHW outlet	1"1/4 M	1"1/2 M

Dimensions in mm



По вопросам продаж и поддержки обращайтесь:

Архангельск (8182)63-90-72

Астана +7(7172)727-132

Белгород (4722)40-23-64

Брянск (4832)59-03-52

Владивосток (423)249-28-31

Волгоград (844)278-03-48

Вологда (8172)26-41-59

Воронеж (473)204-51-73

Екатеринбург (343)384-55-89

Иваново (4932)77-34-06

Ижевск (3412)26-03-58

Казань (843)206-01-48

Калининград (4012)72-03-81

Калуга (4842)92-23-67

Кемерово (3842)65-04-62

Киров (8332)68-02-04

Краснодар (861)203-40-90

Красноярск (391)204-63-61

Курск (4712)77-13-04

Липецк (4742)52-20-81

Магнитогорск (3519)55-03-13

Москва (495)268-04-70

Мурманск (8152)59-64-93

Набережные Челны (8552)20-53-41

Нижний Новгород (831)429-08-12

Новокузнецк (3843)20-46-81

Новосибирск (383)227-86-73

Орел (4862)44-53-42

Оренбург (3532)37-68-04

Пенза (8412)22-31-16

Пермь (342)205-81-47

Ростов-на-Дону (863)308-18-15

Рязань (4912)46-61-64

Самара (846)206-03-16

Санкт-Петербург (812)309-46-40

Саратов (845)249-38-78

Смоленск (4812)29-41-54

Сочи (862)225-72-31

Ставрополь (8652)20-65-13

Тверь (4822)63-31-35

Томск (3822)98-41-53

Тула (4872)74-02-29

Тюмень (3452)66-21-18

Ульяновск (8422)24-23-59

Уфа (347)229-48-12

Челябинск (351)202-03-61

Череповец (8202)49-02-64

Ярославль (4852)69-52-93

сайт: www.ciat.nt-rt.ru | эл. почта: cta@nt-rt.ru